



CROSBY SERIES BP OMNI-TRIM® PRESSURE RELIEF VALVES

INSTALLATION, MAINTENANCE AND ADJUSTMENT INSTRUCTIONS

Before installation these instructions must be read fully and understood



cause misalignment of the valve parts. It is recommended that the valves be left in their original shipping containers and that they be stored in a warehouse or, as a minimum, on a dry surface with a protective covering until they are used.

Pressure relieving valves must be handled carefully and never subjected to sharp impact loads. They should not be struck, bumped or dropped. Rough handling may alter the pressure setting, deform valve parts and affect seat tightness and valve performance adversely.

NOTE

Where valves have levers as in Types D and E top construction, DO NOT LIFT OR CARRY VALVES BY THE LEVERS.

Inlet and outlet protectors should remain in place until the valve is ready to be installed on the system.

must not be used. The flow from the valve must discharge to a safe disposal area.

The safety of lives and property often depends on the proper operation of the pressure relief valves. The valves must be maintained according to appropriate instructions and must be tested periodically and reconditioned to ensure that they function correctly.

Crosby pressure relief valves described in this instruction are manufactured in accordance with the requirements of ASME Boiler and Pressure Vessel Code, Section VIII. Capacities are certified by the National Board of Boiler and Pressure Vessel Inspectors.

TABLE OF CONTENTS

1. General.....	1
2. Storage and handling.....	1
3. Installation.....	1
4. Testing.....	3
5. Set pressure changes.....	3
6. Set pressure adjustment.....	3
7. Maintenance.....	3
8. Assembly of caps and lifting lever devices....	4
9. Replacement spare parts.....	6

1 GENERAL

Crosby valves have been tested and adjusted at the factory. As service conditions differ it may be necessary to make slight adjustments. These adjustments are made easily if the instructions below are followed carefully.

WARNING

To have trouble free performance be sure to clean the inlets and outlets of valves thoroughly before installing.

2 STORAGE AND HANDLING

Often, valves are on hand at the job site months before they are installed. Unless stored and protected properly, valve performance may be affected adversely. Rough handling and dirt may damage or

3 INSTALLATION

3.1 Inlet piping

The valve should be mounted vertically in an upright position either directly on a nozzle from the pressure vessel or on a short connection fitting that provides a direct, unobstructed flow between the vessel and the valve.

Installing a pressure relief valve in other than this recommended position might affect its operation adversely. A valve should never be installed on a fitting having a smaller inside diameter than the inlet connection of the valve. Compliance with the above recommendations will assure clean, positive valve operation. Many valves are damaged when first placed in service because of failure to clean the connections properly when installed.

Both the valve inlet and the vessel and/or line on which the valve is mounted must be cleaned thoroughly of all dirt and foreign material.

3.2 Outlet piping

Discharge piping should be simple and direct. A broken connection near the valve outlet is preferred. The weight of the discharge piping should be carried by a separate support and be braced firmly against swaying or vibrations. Fittings or pipe having a smaller inside diameter than the valve outlet connections

CROSBY SERIES BP OMNI-TRIM® PRESSURE RELIEF VALVES
 INSTALLATION, MAINTENANCE AND ADJUSTMENT INSTRUCTIONS

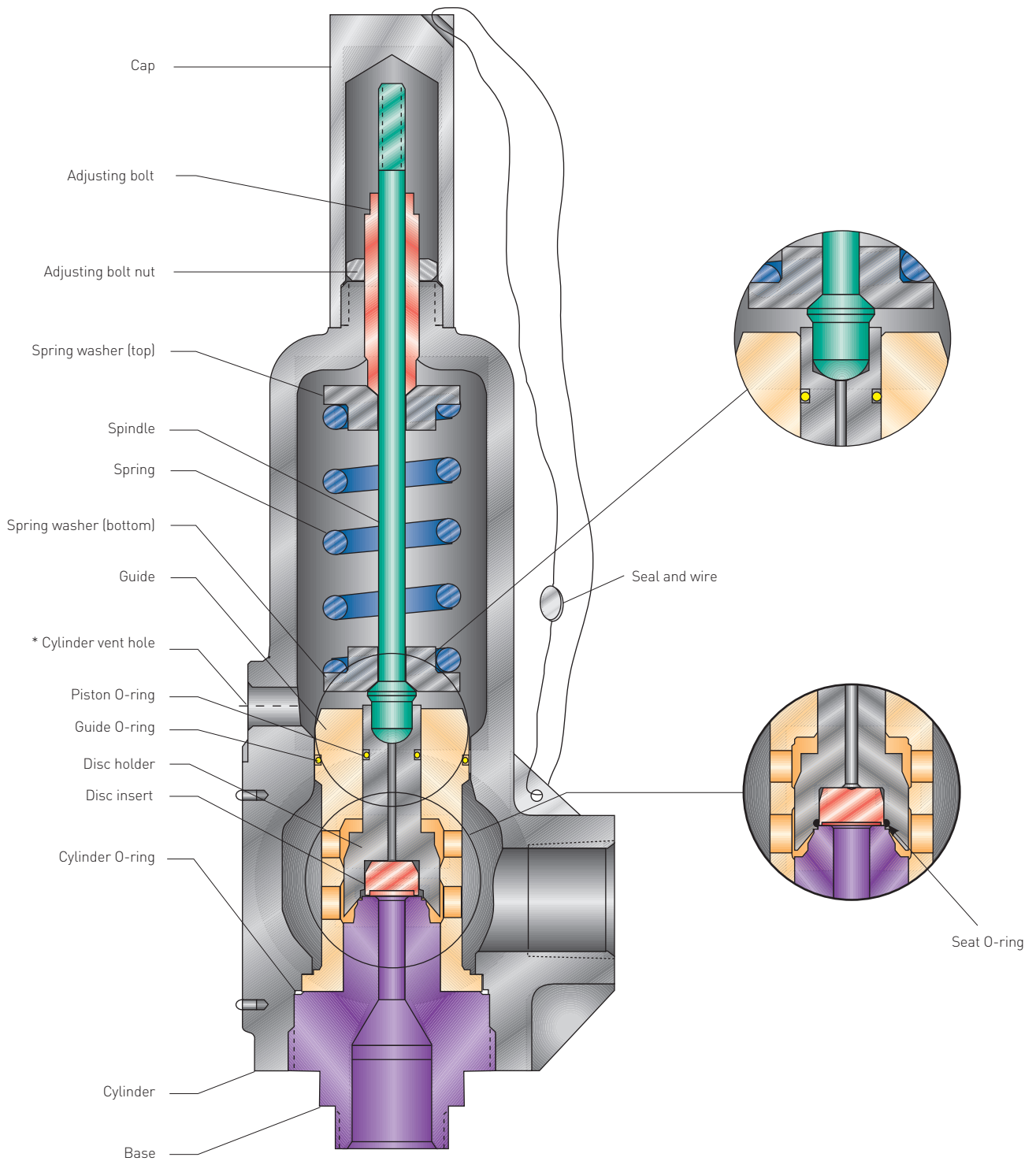

* This vent must remain open

**Threaded connection
 Series BP**

CROSBY SERIES BP OMNI-TRIM® PRESSURE RELIEF VALVES

INSTALLATION, MAINTENANCE AND ADJUSTMENT INSTRUCTIONS

4 TESTING

Testing should be performed by trained personnel using the applicable test procedure. Follow these guidelines for performance of the set pressure test:

4.1 Test fluids - set pressure test

The test fluid should be air or nitrogen for valves used on gas and vapor service and water for valves used on liquid service.

4.2 Temperature correction

When a valve is set on air or water at room temperature and then used at a higher service temperature, the cold differential set pressure shall be corrected to exceed the set pressure using the following temperature correction:

Operating temperature		% Pressure increase
°F	°C	
0 to +150	-18 to +66	-
+151 to 400	+66 to +204	1%

4.3 Valve operation

Valves intended for compressible fluid service and tested on air or nitrogen will open with a sharp, clear popping action at the set point. Valves for liquid service tested with water are considered open at the first continuous unbroken stream of liquid flowing through the valve. Sometimes it is helpful to install a short piece of pipe in the valve outlet to determine the opening on water.

5 SET PRESSURE CHANGES

Set pressure changes beyond the specified spring range will necessitate a change in the valve spring assembly consisting of the spring and two washers.

The new spring and washers must be obtained from Emerson and the valve must be reset and the nameplate restamped by an authorized repair facility.

6 SET PRESSURE ADJUSTMENT

Before making any adjustments, reduce the pressure under the valve seat to at least 25% below the stamped opening pressure. This will prevent seat damage due to turning of the disc insert on the nozzle seat and minimize the chance of an inadvertent opening.

7 MAINTENANCE

7.1 Dismantling

1. Remove the cap.
2. Before removing the adjusting bolt, take a measurement from the top of the adjusting bolt to the top of the cylinder as a reference for resetting the valve later.
3. Loosen the adjusting bolt nut and turn the adjusting bolt counterclockwise to remove the load on the spring completely. Unless this is done, unnecessary damage to the seat or misalignment of the trim parts may occur when the valve is reassembled.
4. Loosen the base from the cylinder but do not remove.
5. Place the valve, upside down, in a vise and remove the base.
6. Remove the guide and disc assembly as a unit. A screwdriver or other suitable tool can be inserted into the cylinder vent hole to facilitate removal of the guide.
7. Remove the disc holder from the guide.
8. Remove the cylinder from the vise and remove the spindle, spring and spring washers.
9. Remove the disc insert by inserting a drive pin or similar tool into the hole in the disc holder and press out the disc insert. Remove the O-ring with a suitable tool. Be careful not to damage the O-ring groove.
10. Remove the guide O-ring, piston O-ring and cylinder O-ring.

Cleaning

The following instructions are general guidelines. Certain applications may require the use of special cleaning procedures.

1. After the valve has been dismantled completely, the seats on both the nozzle and the disc insert should be examined to determine how badly they are damaged, if at all. Any severe damage may make it advisable to replace the parts.
2. External parts, such as the cylinder and cap, can be cleaned by immersion in a bath such as a hot oakite solution or equivalent.
3. Internal parts, except O-rings, can be cleaned using acetone, denatured alcohol or any other suitable solvent. Mechanical cleaning of internal parts, except seats, can be performed using fine sandpaper or emery cloth.

CROSBY SERIES BP OMNI-TRIM® PRESSURE RELIEF VALVES

INSTALLATION, MAINTENANCE AND ADJUSTMENT INSTRUCTIONS

7.2 Assembly

1. Prior to assembly the following surfaces are to be coated with pure nickel "Never-Seez": (see Figure 1)
 - Base to cylinder threads
 - Spring washer bevels
 - Adjusting bolt threads
 - Cap threads
 - Cap to cylinder sealing surfaces
2. Prior to assembly the guide surface of the guide is to be lightly coated with Dow Corning 3451 grease.
3. All O-rings except the piston O-ring and TFE O-rings are to be coated with Dow Corning 3451.
4. The piston O-ring is to be coated with Dow Corning 3451.
5. Place the spring and washers onto the spindle.
6. Place the spindle/washer/spring assembly into the cylinder. With the spindle protruding through the top of the cylinder while inverting the cylinder, place the inverted cylinder into a vise.
7. Coat the entire guide O-ring with Dow Corning 3451 and install on the guide.
8. Coat the entire seat O-ring (except TFE seat) with Dow Corning 3451. Insert the O-ring into the groove in the disc holder. Push the disc insert into the disc holder. Installing the disc insert with a TFE O-ring or a high durometer elastomer may require a small press.
9. Coat the entire piston O-ring with a small amount of Dow Corning 3451 and install onto the disc holder.
10. Install the disc holder into the guide.
11. Install the guide/disc holder assembly into the cylinder.
12. Coat the cylinder O-ring with Dow Corning 3451 and install into the cylinder.
13. Screw the base into the cylinder until tight (locked).
14. Screw the adjusting bolt nut onto the adjusting bolt and install into the cylinder.
15. Screw the cap onto the cylinder with a suitable wrench until tight.

8 ASSEMBLY OF CAPS AND LIFTING LEVER DEVICES

Type A (screwed cap)

Apply pure nickel Never-Seez or equivalent to the cap sealing surface and screw the cap onto the top of the cylinder. Tighten the cap with a suitable wrench.

Type B (screwed cap with test rod)

Apply pure nickel Never-Seez to the cap sealing surface and screw the cap onto the top of the cylinder. Tighten the cap with a suitable wrench. Install the cap plug O-ring and screw the cap plug into the cap. The test rod is installed only during system hydrostatic testing.

Never install the test rod unless performing system hydrostatic testing.

Type D (packed lifting lever)

1. Apply Loctite 242 or equivalent to the spindle threads. Screw the spindle nut onto the spindle. Screw the cap hand tight.
2. Apply Dow Corning 3451 or equivalent to the cam O-ring and install onto the cam. Insert the cam into the sleeve. Install the lever onto the cam and secure with the lever pin.
3. Screw the lever assembly into the cap. If the cam interferes with spindle nut, remove the spindle assembly and raise the spindle nut. Repeat until the spindle nut is approximately $\frac{1}{16}$ " above the cam.
4. Once the spindle nut is in position, remove the cap and screw the locknut on the spindle and, while securing the spindle nut firmly with locking pliers, tighten the locknut.
5. Apply pure nickel Never-Seez or equivalent to the cap threads and to the cap sealing surface. Screw the cap onto the top of the cylinder. Tighten the cap with a suitable wrench.
6. Apply Dow Corning 3451 or equivalent to the cam sleeve O-ring and install the O-ring. Install the lever assembly.

Type E (packed lifting lever with test rod)

Assembly of the Type E lifting lever is identical to the Type D with the addition of the cap plug O-ring and the cap plug. The test rod is installed only during system hydrostatic testing.

Never install the test rod unless performing system hydrostatic testing.

CROSBY SERIES BP OMNI-TRIM® PRESSURE RELIEF VALVES

INSTALLATION, MAINTENANCE AND ADJUSTMENT INSTRUCTIONS

FIGURE 1

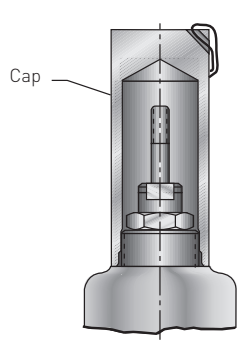
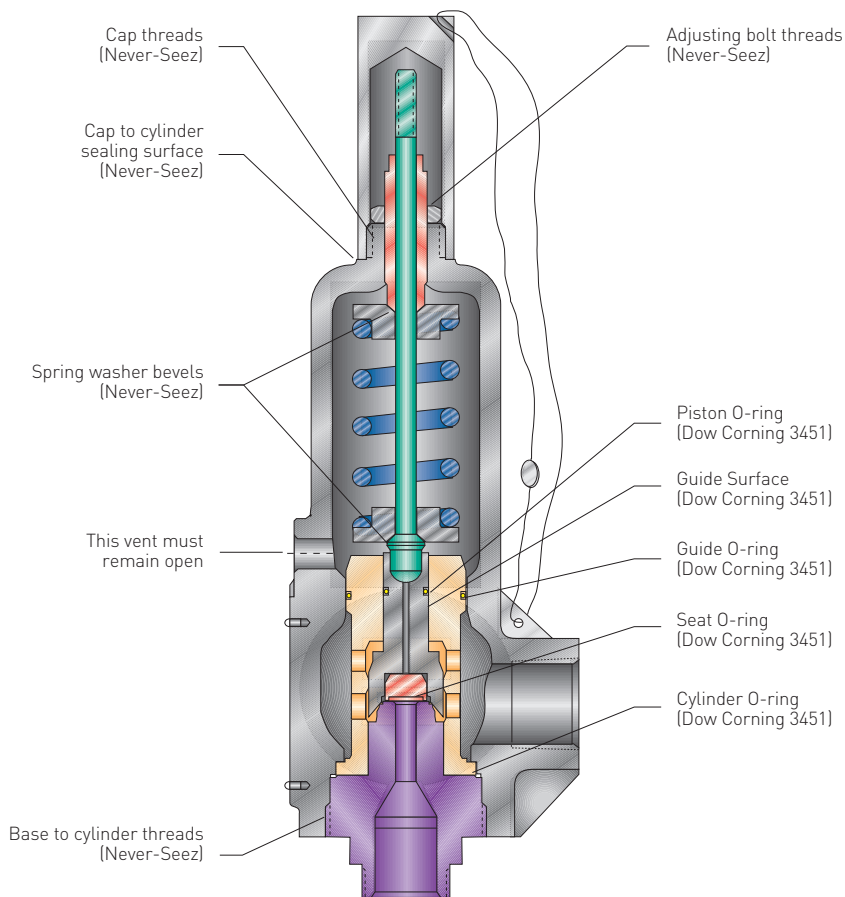

Type A

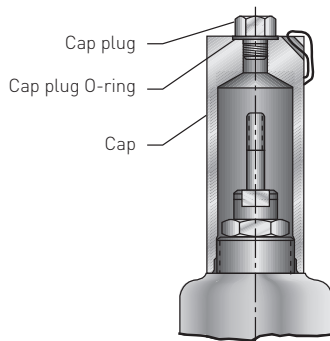

Type B

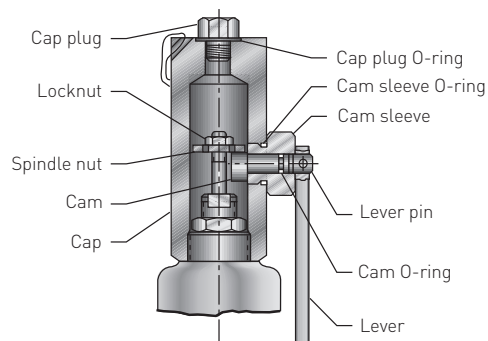

Type E

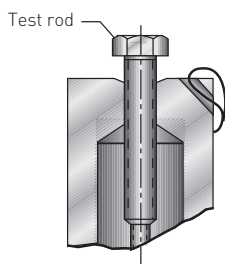

View showing valve gagged with test rod

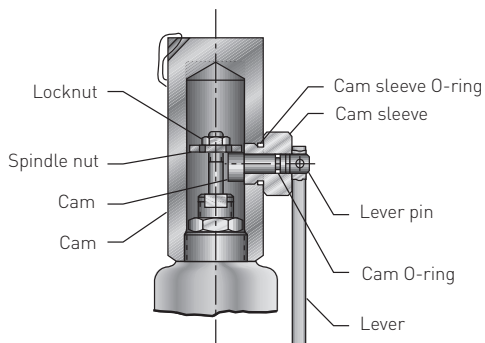

Type D

CROSBY SERIES BP OMNI-TRIM® PRESSURE RELIEF VALVES

INSTALLATION, MAINTENANCE AND ADJUSTMENT INSTRUCTIONS

9 REPLACEMENT SPARE PARTS

9.1 Ordering information

Emerson recommends that a sufficient inventory of spare parts be maintained to support process requirements. Always be sure to use genuine Emerson parts to ensure continued product performance and warranty.

9.2 Parts

To order parts, the following information always should be included:

1. Quantity
2. Part name, i.e. (disc insert)
3. Size, style, type and valve number
4. Shop and/or serial number
5. Original purchase order number
(if the nameplate has been destroyed)

NOTE

The size, style, shop number, set pressure and serial number can always be found on the valve nameplate.

9.3 Springs with washers

To order springs with washers, the required valve set pressure must also be specified in addition to the other parts information. Should back pressure (fixed or variable) or elevated temperature exist during operation, also specify these conditions. Emerson provides special 'fast response' delivery service of spare parts to satisfy unplanned parts requirements. Fast response delivery service can be initiated by contacting your local Emerson representative. Emerson.com/FinalControl

For additional information about Series BP OMNI-TRIM pressure relief valves, see VCTDS-00594.