



KEYSTONE SERIES GR RESILIENT SEATED BUTTERFLY VALVES

GRW/GRL (ISO)

A heavy duty industrial resilient seated butterfly valve



FEATURES

- Wafer and lugged body design with face-to-face dimension, according to EN 558 Series 20 and API 609.
- Designed according to EN 593 and API 609.
- The seat is field replaceable and fully isolates the body and shaft from the flow.
- Primary shaft sealing exceeds the pressure rating of the valve and prevents leakage through shaft area to atmosphere.
- A secondary shaft sealing provides back-up safety.
- A molded-in O-ring in the seat for flange sealing eliminates the need for gaskets.
- Shaft seals prevent moisture penetrating into the shaft area.
- The two piece shaft allows for a thin disc and provides minimal obstruction to flow (up to DN 300).
- Rounded polished disc edge gives full concentric sealing, lower torques, longer seat life and drop-tight shut-off.
- Body locating holes allow ease of installation and centering between the flanges.
- Extended body neck allows for pipe insulation.
- Actuator flange according to ISO 5211.
- Top and bottom shaft bearings for optimized support and minimum friction and decreased torque.
- Top bushing absorbs actuator side thrust loads.
- All valves comply to Pressure Equipment Directive (2014/68/EU) Module B + D, CE Marking.
- Available approvals: NSF/ANSI 61, ACS, KIWA, WRAS, DVGW-G, ABS, CU-TR.
- Sizes DN 20 up to DN 40 might deviate from the above mentioned features. Please contact factory.

GENERAL APPLICATION

Water, air, dry bulk conveying etc. These valves are for any service where a drop-tight shut-off with maximum flow area is required.

TECHNICAL DATA

Sizes:	DN 20 - 900
Pressure:	16 bar DN 20 - 300 10 bar DN 350 - 900 Reinforced seat: 16 bar DN 350 - 600
End of line:	10 bar DN 20 - 300 6 bar DN 350 - 900 Reinforced seat: 10 bar DN 350 - 600
Vacuum service:	0.4 bar
Temperature:	-28°C to +160°C
Flange accommodation:	PN 6/10/16 ASME 125/150 JIS 10K BS Table E AS4087 PN 16 AS2129 Table E

KEYSTONE SERIES GR RESILIENT SEATED BUTTERFLY VALVES

GRW/GRL (ISO)

SERIES GRW/GRL

DN 50-300
(GRW SHOWN)

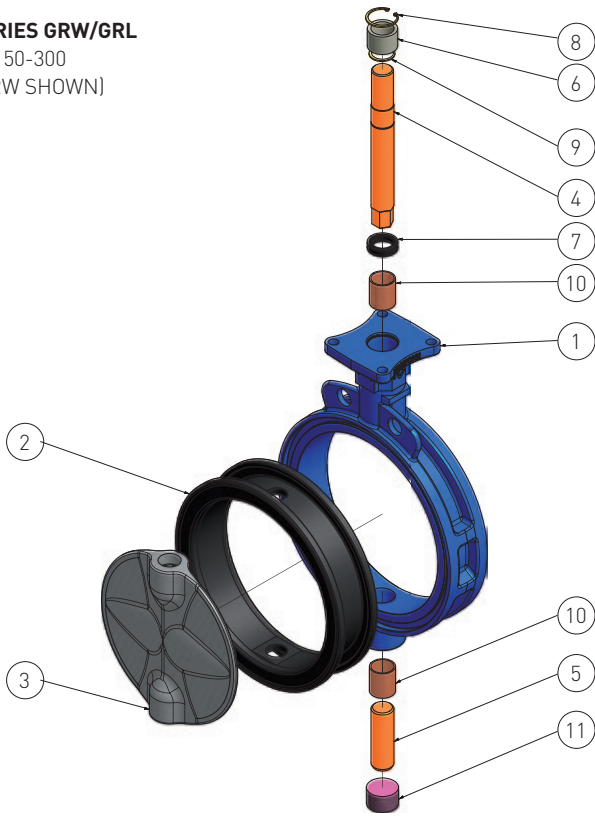

PARTS LIST

Item	Qty	Description
1	1	Body
2	1	Seat
3	1	Disc
4	1	Upper shaft
5	1	Lower shaft
6	1	Upper bushing
7	1	Packing
8	1	Body circlip
9	1	Shaft circlip
10	2	Upper and lower bearing
11	1	Plug

DN 350-900
(GRL SHOWN)

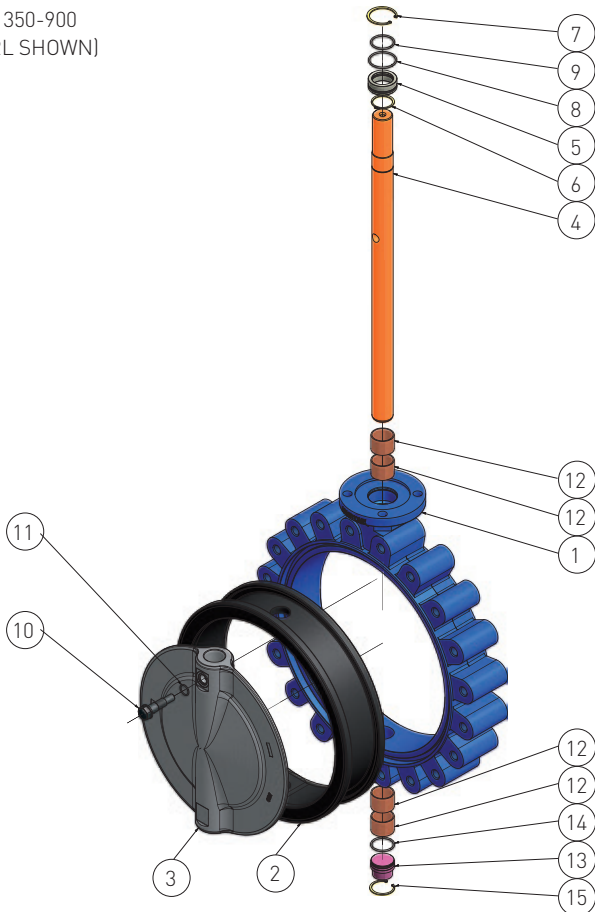

PARTS LIST

Item	Qty	Description
1	1	Body
2	1	Seat
3	1	Disc
4	1	Shaft
5	1	Bushing
6	1	Shaft circlip
7	1	Body circlip
8	1	Body O-ring
9	1	Shaft O-ring
10	1	Disc screw
11	1	Disc screw O-ring
12	4	Upper and lower bearing
13	1	Plug
14	1	Plug O-ring
15	1	Plug circlip

KEYSTONE SERIES GR RESILIENT SEATED BUTTERFLY VALVES

GRW/GRL (ISO)

MATERIAL SPECIFICATION (DN 20-300)

Part name	Material	Designation	EN/DIN mat.no	Remark
DN 20-40				
Body	Ductile iron	GJS-400-15	EN JS-1030	
Disc	Stainless steel	GX5CrNiMo19-11-2	EN 1.4408	Comparable with CF8M
Shaft	Stainless steel	X17CrNi16-2	EN 1.4057	Similar to ASTM A276/Gr. 431
Seat	EPDM NBR EPDM-A EPDM-WA3			
DN 50-300				
Body	Ductile iron	GJS-400-15	EN JS-1030	Dual certified to ASTM A536-65-45-12
Disc	Super duplex	GX2CrNiMoN26-7-4	EN 1.4469	
	316 stainless steel	GX5CrNiMo19-11-2	EN 1.4408	Comparable with CF8M
	304 stainless steel	GX5CrNiMo19-10	EN 1.4308	Comparable with CF8
	Aluminium bronze	CuAl10Fe2-C	EN CC331G	
	Nickel aluminium bronze	CuAl10Fe5Ni5	EN CC333G	
	Ductile iron NYL	GJS-400-15	EN JS-1030	NYL = Nylon coating, max. temp. 60°C
	Ductile iron CTD	GJS-400-15	EN JS-1030	CTD = Nickel plating
Shaft	316 stainless steel	X5CrNiMo17-12-2	EN 1.4401	
	431 stainless steel	X17CrNi16-2	EN 1.4057	
	Super duplex	GX2CrNiMoN25-7-4	EN 1.4410	
	Monel® K500	DIN 17752	EN 2.4375	
Seat	EPDM EPDM E1 NBR NBR N1 HNBR White NBR FKM			Food grade, NSF/ANSI 61, ACS KIWA, WRAS, ACS Food grade DVGW-G
Bushing	Polyester			
Packing	NBR			
Bearing	PTFE/steel			
Circlip	Stainless steel			
Plug	Carbon steel			

NOTES

Valves with super duplex disc will have super duplex disc screw. All other discs will have a duplex disc screw.

Monel® is a registered trademark of Special Metals Corporation.

KEYSTONE SERIES GR RESILIENT SEATED BUTTERFLY VALVES

GRW/GRL (ISO)

MATERIAL SPECIFICATION (DN 350-900)

Part name	Material	Designation	EN/DIN mat.no	Remark
DN 350-900				
Body	Ductile iron	GJS-400-15	EN JS-1030	Dual certified to ASTM A536-65-45-12
Disc	Super duplex	GX2CrNiMoN26-7-4	EN 1.4469	
	Duplex	GX2CrNiMoN22-5-3	EN 1.4470	
	316 stainless steel	GX5CrNiMo19-11-2	EN 1.4408	Comparable with CF8M
	304 stainless steel	GX5CrNiMo19-10	EN 1.4308	Comparable with CF8
	Aluminium bronze	CuAl10Fe2-C	EN CC331G	
	Nickel aluminium bronze	CuAl10Fe5Ni5	EN CC333G	Comparable with BS 1400 AB2
	Ductile iron NYL	GJS-400-15	EN JS-1030	NYL = Nylon coating, max. temp. 60°C
	Ductile iron CTD	GJS-400-15	EN JS-1030	CTD = Epoxy coated, max. temp. 120°C
Shaft	431 stainless steel	X17CrNi16-2	EN 1.4057	Similar to ASTM A276/Gr. 431
	Duplex	X2CrNiMoN22-5-3	EN 1.4462	
	Super duplex	X2CrNiMoN25-7-4	EN 1.4410	
	Monel® K500	DIN 17752	EN 2.4375	
Seat	EPDM			Food grade, NSF/ANSI 61, ACS
	EPDM E1			KIWA, WRAS, ACS
	NBR			Food grade
	NBR N1			DVGW-G
	HNBR			
	FKM			
Disc screw	Super duplex	GX2CrNiMoN25-7-4	EN 1.4410	
	Duplex	X2CrNiMoN22-5-3	EN 1.4462	
Disc screw O-ring	EPDM			
	NBR			
	FKM			
Plug	Carbon steel			
Plug O-ring	NBR			
Plug circlip	Stainless steel			
Bushing	Polyester			
Shaft/Body O-ring	NBR			
Bearing	PTFE/steel			
Shaft/Body circlip	Stainless steel			

MATERIAL SPECIFICATION (DN 350-600) REINFORCED SEAT

Part name	Material	Designation	EN/DIN mat.no	Remark
DN 350-600				
Body	Ductile iron	GJS-400-15	EN JS-1030	Dual certified to ASTM A536-65-45-12
Disc	Stainless steel	GX5CrNiMo19-11-2	EN 1.4408	Comparable with CF8M
	Nickel aluminium bronze	CuA10Fe5Ni5	EN CC333G	Comparable with BS 1400 AB2
	Ductile iron CTD	GJS-400-15	EN JS-1030	CTD = Epoxy coated, max. temp. 120°C
Shaft	431 Stainless steel	X17CrNi16-2	EN 1.4057	Similar to ASTM A276/Gr. 431
	Super duplex	X2CrNiMoN25-7-4	EN 1.4410	
Seat	XEPDM			
	XNBR			
Disc screw	Duplex	X2CrNiMoN22-5-3	EN 1.4462	
Disc screw O-ring	NBR			
Plug	Carbon steel			
Plug O-ring	NBR			
Plug circlip	Stainless steel			
Brushing	Polyester			
Shaft/body O-ring	NBR			
Bearing	PTFE/steel			
Shaft/body circlip	Stainless steel			

NOTES

Valves with super duplex disc will have super duplex disc screw. All other discs will have a duplex disc screw.

Monel® is a registered trademark of Special Metals Corporation.

KEYSTONE SERIES GR RESILIENT SEATED BUTTERFLY VALVES

GRW/GRL (ISO)

SERIES GRW (WAFFER)

DN 50-300

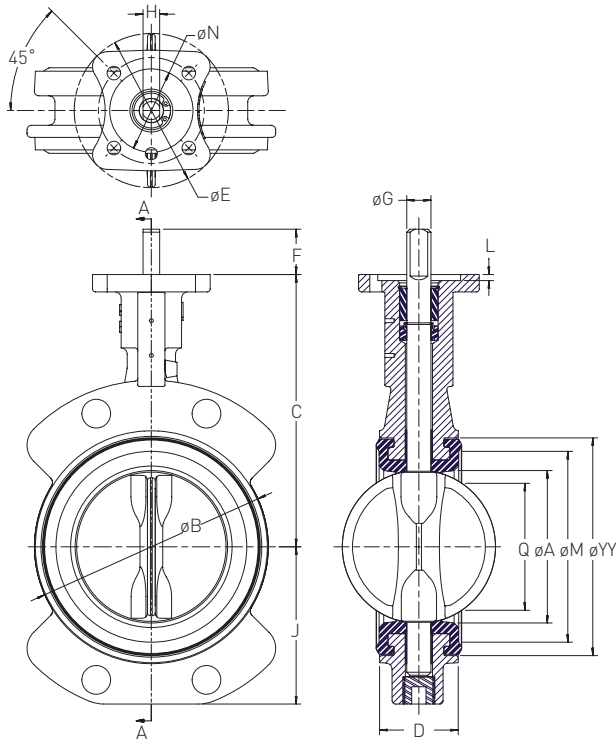

DN 350-900

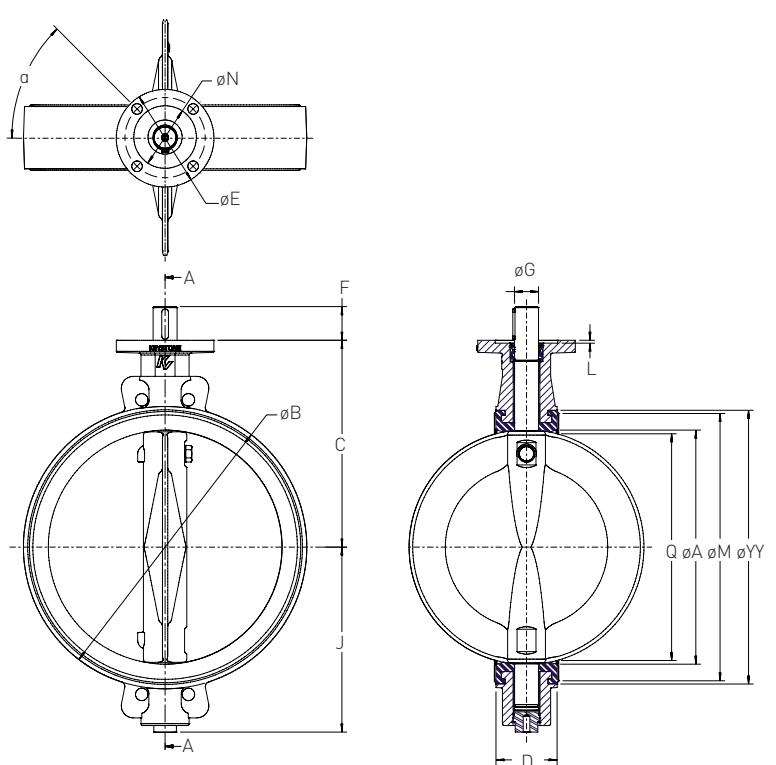

VALVE DIMENSIONS (mm)

Size ⁽¹⁾ (DN)	A	B	C	D	E	F	J	L	M	N	Q ⁽²⁾	YY	Shaft			Top plate drilling			Adapt. code	Weight ⁽⁴⁾ (kg)	
													G	H ⁽³⁾	Key	Bolt circle	No. holes	a			Holes dia.
20	30	61	115	25	65	25	49	4	38	35	18	50	12	8	-	50	4	45°	6.6	F05	1.0
25	30	61	115	25	65	25	49	4	38	35	18	50	12	8	-	50	4	45°	6.6	F05	1.0
32	40	78	130	33	65	25	61	4	49	35	25	64	12	8	-	50	4	45°	6.6	F05	1.5
40	40	78	130	33	65	25	61	4	49	35	25	64	12	8	-	50	4	45°	6.6	F05	1.5
50	50	91	135	43	65	25	60	4	66	35	28	80	12	8	-	50	4	45°	7.0	F05	1.8
65	62	105	150	46	100	30	76	4	78	55	43	93	16	11	-	70	4	45°	9.0	F07	2.7
80	77	123	160	46	100	30	82	4	97	55	65	112	16	11	-	70	4	45°	9.0	F07	3.2
100	99	154	180	52	100	30	104	4	129	55	87	144	16	11	-	70	4	45°	9.0	F07	4.5
125	124	187	195	56	100	30	120	4	160	55	113	175	20	14	-	70	4	45°	9.0	F07	6.1
150	150	208	210	56	90	30	131	4	181	55	142	196	20	14	-	70	4	45°	9.0	F07	6.8
200	195	265	240	60	90	30	162	4	233	55	188	248	20	14	-	70	4	45°	9.0	F07	11.3
250	245	320	275	68	150	30	198	4	290	85	237	305	25	18	-	125	4	45°	13.5	F12	19.1
300	291	372	310	78	150	50	230	4	340	85	283	355	30	22	-	125	4	45°	13.5	F12	26.8
350	325	416	325	78	150	70	260	4	378	85	318	398	35	-	10 x 8	125	4	45°	13.5	F12	40.0
400	380	474	360	102	200	70	298	6	435	130	368	455	40	-	12 x 8	165	4	45°	22.0	F16	63.0
450	434	534	395	114	200	70	334	6	495	130	421	515	40	-	12 x 8	165	4	45°	22.0	F16	86.0
500	486	589	430	127	200	70	385	6	549	130	471	569	50	-	14 x 9	165	4	45°	22.0	F16	106.0
600	585	691	500	154	200	70	456	6	650	130	568	670	60	-	18 x 11	165	4	45°	22.0	F16	158.0
700	685	800	570	165	200	80	518	6	755	130	668	775	70	-	20 x 12	165	4	45°	22.0	F16	231.0
750	735	862	605	190	200	90	551	6	816	130	713	835	70	-	20 x 12	165	4	45°	22.0	F16	290.0
800	785	907	640	190	300	90	583	6	860	200	765	880	70	-	20 x 12	254	8	22.5°	17.5	F25	326.0
900	885	1007	715	203	300	100	659	6	960	200	864	980	80	-	22 x 14	254	8	22.5°	17.5	F25	419.0

NOTES

- Sizes 20-40 differ from above images.
- 'Q' dimension is the minimum allowable pipe or flange inside diameter at the centered body face to protect the disc sealing edge against damage when opening the valve.
- 'H' dimension refers to flat on shaft.
- Weight may vary depending on trim materials used.
- øYY dimension is to the outside of the seat
- øM dimension is to the O-ring seal

KEYSTONE SERIES GR RESILIENT SEATED BUTTERFLY VALVES

GRW/GRL (ISO)

SERIES GRL (LUG)

DN 50-300

DN 350-900

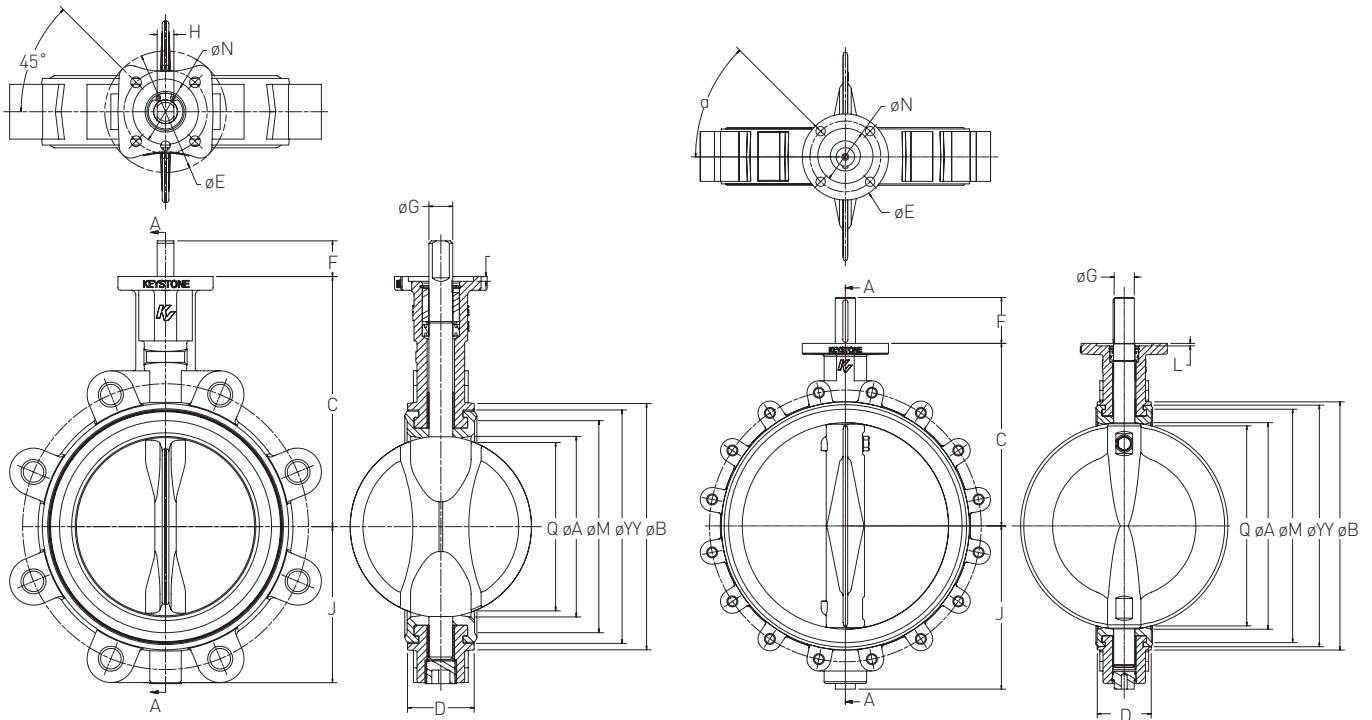

VALVE DIMENSIONS (mm)

Size ⁽¹⁾ (DN)													Shaft			Top plate drilling			Adapt. code	Weight ⁽⁴⁾ (kg)	
	A	B	C	D	E	F	J	L	M	N	Q ⁽²⁾	YY	G	H ⁽³⁾	Key	Bolt circle	No. holes	Holes dia.			
20	30	61	115	25	65	25	43	4	38	35	18	50	12	8	-	50	4	45°	6.6	F05	1.4
25	30	61	115	25	65	25	43	4	38	35	18	50	12	8	-	50	4	45°	6.6	F05	1.4
32	40	78	130	33	65	25	55	4	58	35	25	66	12	8	-	50	4	45°	6.6	F05	2.1
40	40	78	130	33	65	25	55	4	58	35	25	66	12	8	-	50	4	45°	6.6	F05	2.1
50	50	92	135	43	65	25	60	4	66	35	28	80	12	8	-	50	4	45°	7.0	F05	2.7
65	62	105	150	46	100	30	76	4	78	55	43	93	16	11	-	70	4	45°	9.0	F07	4.0
80	77	126	160	46	100	30	82	4	97	55	65	112	16	11	-	70	4	45°	9.0	F07	4.3
100	99	156	180	52	100	30	104	4	129	55	87	144	16	11	-	70	4	45°	9.0	F07	7.0
125	124	190	195	56	100	30	120	4	160	55	113	175	20	14	-	70	4	45°	9.0	F07	10.0
150	150	214	210	56	100	30	131	4	181	55	142	196	20	14	-	70	4	45°	9.0	F07	11.0
200	195	268	240	60	90	30	162	4	233	55	188	248	20	14	-	70	4	45°	9.0	F07	17.0
250	245	321	275	68	150	30	198	4	290	85	237	305	25	18	-	125	4	45°	13.5	F12	29.5
300	291	375	310	78	150	50	230	4	340	85	283	355	30	22	-	125	4	45°	13.5	F12	41.0
350	325	416	325	78	150	70	260	4	378	85	318	398	35	-	10 x 8	125	4	45°	13.5	F12	52.0
400	380	474	360	102	200	70	298	6	435	130	368	455	40	-	12 x 8	165	4	45°	22.0	F16	88.0
450	434	534	395	114	200	70	334	6	495	130	421	515	40	-	12 x 8	165	4	45°	22.0	F16	107.0
500	486	589	430	127	200	70	385	6	549	130	471	569	50	-	14 x 9	165	4	45°	22.0	F16	161.0
600	585	691	500	154	200	70	456	6	650	130	568	670	60	-	18 x 11	165	4	45°	22.0	F16	235.0
700	685	800	570	165	200	80	518	6	755	130	668	775	70	-	20 x 12	165	4	45°	22.0	F16	315.0
750	735	862	605	190	200	90	551	6	816	130	713	835	70	-	20 x 12	165	4	45°	22.0	F16	378.0
800	785	907	640	190	300	90	583	6	860	200	765	880	70	-	20 x 12	254	8	22.5°	17.5	F25	438.0
900 ⁽⁵⁾	885	1007	715	203	300	100	659	6	960	200	864	980	80	-	22 x 14	254	8	22.5°	17.5	F25	559.0

NOTES

- Sizes 20-40 differ from above images.
- 'Q' dimension is the minimum allowable pipe or flange inside diameter at the centered body face to protect the disc sealing edge against damage when opening the valve.
- 'H' dimension refers to flat on shaft.
- Weight may vary depending on trim materials used.
- Valve size DN 900 is tapped flange design and has no separate lugs.
- ØYY dimension is to the outside of the seat
- ØM dimension is to the O-ring seal

KEYSTONE SERIES GR RESILIENT SEATED BUTTERFLY VALVES

GRW/GRL (ISO)

SERIES GRW AND GRL

Note: All holes in lugged version are through threaded, except the holes closest to top and bottom shaft.

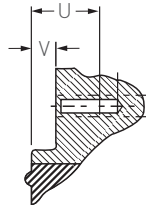

DIMENSIONS OF TAPPED FLANGE LOCATING HOLES (mm)

Size (DN)	Series GRW		Series GRL	
	U	V	U	V
700	45.5	5.5	45.5	5.5
750	65.0	25.0	45.5	5.5
800	60.0	20.0	45.5	5.5
900	54.5	6.5	54.5	6.5

TORQUE APPLICATION FACTOR CATEGORIES

Application I

Clean liquid lubricating media (water, clean oils, lube oil, mineral oil, etc.); and with no deposit or chemical attack, valve operated at least once a week.

Temperature range from 0°C to maximum temperature rating of the elastomer seat.

Application II

Other liquid media and lubricating gases (aqueous liquids, such as food and beverage, water, etc.); and with minor deposit or chemical attack, valve operated at least once a month.

Temperature range from 0°C to maximum temperature rating of the elastomer seat.

Application III

a. Dry non-abrasive media or gases (non-abrasive powders and dry gas); or
b. Fluids with moderate deposit or chemical attack; or
c. Valves operated less than once a month.

Temperature range from 0°C to maximum temperature rating of the elastomer seat.

Application IV

a. Dry abrasive media and degreasing applications (sand, cement, silicone free, oxygen cleaned); or
b. Liquids with severe deposit; or

c. Valves not frequently operated (once a year). All above with temperature range from -10°C to maximum temperature rating of the elastomer seat.

NOTES

- For applications with temperatures above or below the guidelines above, please consult factory.
- For dry service valves it is suggested to use U/C discs (reduced diameter) when service conditions are less than 3.5 bar.

VALVE SEATING AND UNSEATING TORQUES (Nm)

Differential pressure (bar)	Valve size (DN)																					
	20	25	32	40	50	65	80	100	125	150	200	250	300	350	400	450	500	600	700	750	800	900
I*																						
3.5	7	7	10	10	13	19	26	37	58	81	148	241	345	467	639	845	1089	1700	2494	2967	3495	4422
7	7	7	10	10	13	20	27	40	63	88	164	271	387	520	719	960	1248	1979	2943	3521	4169	5275
10	7	7	11	11	14	21	30	44	70	99	188	315	451	595	832	1123	1473	2373	3575	⁽¹⁾ 4302	5120	6479
14	7	7	11	11	15	23	33	49	80	113	219	374	536	-	-	-	-	-	-	-	-	-
16	8	8	12	12	15	25	36	51	85	120	235	403	578	-	-	-	-	-	-	-	-	-
3.5 (U/C)	-	-	-	-	8	11	16	22	35	49	89	145	207	280	383	507	653	1020	1497	1780	2097	2653
II*																						
3.5	7	7	10	10	14	21	29	42	66	93	169	274	392	528	718	945	1212	1877	2736	3245	3811	4822
7	7	7	11	11	14	22	31	45	71	100	185	303	434	580	796	1058	1369	2153	3180	3793	4479	5667
10	7	7	11	11	15	23	33	49	78	111	208	347	498	652	906	1217	1590	2542	3804	⁽¹⁾ 4565	5419	6858
14	8	8	12	12	16	26	36	54	88	125	240	406	583	-	-	-	-	-	-	-	-	-
16	8	8	12	12	17	27	38	56	93	132	255	436	626	-	-	-	-	-	-	-	-	-
3.5 (U/C)	-	-	-	-	8	13	17	25	40	56	101	164	235	317	431	567	727	1126	1642	1947	2287	2893
III*																						
3.5	7	7	11	11	15	23	32	48	74	105	190	306	439	588	797	1045	1336	2055	2978	3523	4127	5222
7	7	7	11	11	16	24	34	50	79	112	206	336	481	639	874	1156	1490	2328	3417	⁽¹⁾ 4065	4788	6059
10	8	8	12	12	16	26	36	54	86	122	229	380	545	709	981	1312	1707	2710	⁽¹⁾ 4034	^(1,2) 4828	⁽²⁾ 5719	7237
14	8	8	13	13	17	28	40	59	96	136	261	439	629	-	-	-	-	-	-	-	-	-
16	8	8	13	13	18	29	41	61	101	143	276	468	672	-	-	-	-	-	-	-	-	-
3.5 (U/C)	-	-	-	-	9	14	19	29	44	63	114	184	263	353	478	627	801	1233	1787	2114	2476	3133
IV*																						
3.5	7	7	12	12	17	26	37	55	86	122	221	355	509	679	915	1195	1521	2322	3341	3940	4601	5822
7	8	8	13	13	18	27	39	58	91	129	237	384	551	728	990	1303	1671	2589	3772	⁽¹⁾ 4473	5252	6646
10	8	8	13	13	18	29	41	62	99	140	260	428	615	795	1094	1454	1883	2963	⁽¹⁾ 4378	^(1,2) 5223	⁽²⁾ 6168	7805
14	8	8	13	13	19	31	45	67	108	154	292	487	700	-	-	-	-	-	-	-	-	-
16	8	8	13	13	20	32	46	69	113	161	307	517	742	-	-	-	-	-	-	-	-	-
3.5 (U/C)	-	-	-	-	10	16	22	33	52	73	133	213	305	408	549	717	913	1393	2005	2364	2761	3493

NOTES

* Application I, II, III, IV

3.5 U/C refers to reduced diameter disc option.

1. Use a minimum of Class 8.8 steel bolts to connect actuator to valve.

2. Duplex shaft not suitable for these conditions, use only 431 stainless steel or super duplex.

KEYSTONE SERIES GR RESILIENT SEATED BUTTERFLY VALVES

GRW/GRL (ISO)

VALVE SEATING AND UNSEATING TORQUES (Nm) (REINFORCED SEAT)

Differential pressure (bar)	Valve size (DN)				
	350	400	450	500	600
I*					
10	851	1173	1563	2026	3198
14	986	1374	1849	2419	3876
16	1053	1474	1992	2615	4216
II*					
10	947	1298	1721	2221	3879
14	1081	1499	2007	2614	4157
16	1149	1599	2150	2810	4496
III*					
10	1297	1755	2300	2936	4509
14	-	-	-	-	-
16	-	-	-	-	-

NOTES

As the reinforced seat is intended for high pressure applications the base torque commences at 1000 kPa/10 bar.

Reinforced seat are suitable for:

- Severe vacuum application (use 10 bar torque values).
- High line velocities up to 12 m/s for liquids.
- Pressure testing during erection and commissioning.

TORQUE APPLICATION FACTOR CATEGORIES

Application I

Clean liquid lubricating media (water, clean oils, lube oil, mineral oil, etc.); and with no deposit or chemical attack, valve operated at least once a week.

Temperature range from 0°C to maximum temperature rating of the elastomer seat.

Application II

Other liquid media and lubricating gases (aqueous liquids, such as food and beverage, water, etc.); and with minor deposit or chemical attack, valve operated at least once a month.

Temperature range from 0°C to maximum temperature rating of the elastomer seat.

Application III

- a. Dry non-abrasive media or gases (non-abrasive powders and dry gas); or
- b. Fluids with moderate deposit or chemical attack; or
- c. Valves operated less than once a month.

Temperature range from 0°C to maximum temperature rating of the elastomer seat.

NOTE

1. For applications with temperatures above or below the guidelines above, please consult factory.

KEYSTONE SERIES GR RESILIENT SEATED BUTTERFLY VALVES

GRW/GRL (ISO)

MAXIMUM ALLOWABLE SHAFT TORQUES (Nm)

Shaft material	Valve size (DN)																					
	20	25	32	40	50	65	80	100	125	150	200	250	300	350	400	450	500	600	700	750	800	900
316SS (SS 1.4401)	-	-	-	-	65	160	160	160	320	320	320	545	970	-	-	-	-	-	-	-	-	-
431SS (SS 1.4057)	20	20	90	90	90	230	230	230	460	460	460	935	1660	1470	1824	2448	3308	5346	6300	6300	7560	11424
Duplex (SS 1.4462)	-	-	-	-	-	-	-	-	-	-	-	-	-	1103	1368	1836	2481	3341	4725	4725	5670	8568
Super duplex (SS 1.4410)	-	-	-	-	85	210	210	210	420	420	420	855	1520	1348	1727	2390	3032	4589	5408	5408	6489	9806
Monel® K500 (2.4375)	-	-	-	-	76	190	190	190	381	381	381	777	1381	1225	1520	2040	2756	3713	5250	5250	6300	9520

FLOWRATE CO-EFFICIENTS - K_v VALUES

Valve size (DN)	Disc opening (degrees)									
	10°	20°	30°	40°	50°	60°	70°	80°	90°	
20	-	0.2	0.5	1.3	2.8	4.5	8.3	12.8	19.0	
25	-	0.2	0.5	1.3	4.5	10.3	17.7	26.5	31.0	
32	-	0.6	2.0	6.0	14.8	23.5	36.0	49.8	54.0	
40	-	0.6	2.0	6.0	16.0	28.0	43.0	55.0	56.0	
50	0	0.9	4.8	14	30	47	72	99	108	
65	0	2.4	11	27	50	78	123	172	217	
80	0	6	28	55	91	141	215	304	409	
100	0	14	57	109	177	265	407	600	807	
125	0	28	85	158	250	389	630	964	1251	
150	7	52	130	226	367	578	987	1551	1946	
200	22	115	231	405	646	1029	1773	2910	3516	
250	34	173	339	641	980	1546	2677	4449	5806	
300	49	253	495	935	1430	2255	3905	6710	8910	
350	119	304	637	1142	1936	3110	5010	8969	10407	
400	155	397	832	1492	2529	4062	6544	11714	13592	
450	196	503	1053	1888	3200	5141	8288	14826	17203	
500	242	621	1300	2331	3951	6347	10224	18303	21238	
600	349	894	1871	3357	5689	9140	14723	26357	30583	
700	475	1216	2547	4569	7744	12440	20040	35875	41626	
750	545	1396	2924	5245	8890	14281	23005	41183	47785	
800	620	1589	3327	5968	10114	16248	26174	46857	54369	
900	785	2011	4211	7553	12801	20564	33127	59303	68811	

NOTE

K_v = The volume of water in m³/hr that will pass through a valve with a pressure drop of 1 bar at 20°C

PRESSURE-TEMPERATURE DIAGRAM

Seat material*	Disc material**	Body material	Size range (DN)	Valve function Standard / End of Line	Temperature (°C)								
					-28	-20	-15	0	50	100	120	130	150
EPDM	all	DI	50-300	Std / EOL				16 bar / 10 bar					
NBR and white NBR	all	DI	50-300	Std / EOL				16 bar / 10 bar					
HNBR	all	DI	50-300	Std / EOL				16 bar / 10 bar					
FKM	all	DI	50-300	Std / EOL				16 bar / 10 bar				10 bar / 6 bar	
E1 EPDM	all	DI	50-300	Std / EOL				16 bar / 10 bar					
EPDM	all	DI	350-900	Std / EOL				10 bar / 6 bar					
NBR	all	DI	350-900	Std / EOL				10 bar / 6 bar					
HNBR	all	DI	350-900	Std / EOL				10 bar / 6 bar					
FKM	all	DI	350-900	Std / EOL				10 bar / 6 bar				6 bar / 4 bar	
XEPDM	all	DI	350-600	Std / EOL				16 bar / 10 bar					
XNBR	all	DI	350-600	Std / EOL				16 bar / 10 bar					

*All seat materials drop tight

**Per material listed in the material specification tables

Minimum temperature size range DN 20-40: -10°C

KEYSTONE SERIES GR RESILIENT SEATED BUTTERFLY VALVES

GRW/GRL (ISO)

SELECTION GUIDE

Example:	GRL	0100	-	D0	A1	S2	E0	A1	I	-	00	000	00
Series	GR												
Body style													
GRL	Lug												
GRW	Wafer												
Size													
0020	DN 20/NPS ¾		0250		DN 250/NPS 10								
0025	DN 25/NPS 1		0300		DN 300/NPS 12								
0032	DN 38/NPS 1½		0350		DN 350/NPS 14								
0040	DN 40/NPS 1½		0400		DN 400/ NPS 16								
0050	DN 50/NPS 2		0450		DN 450/NPS 18								
0065	DN 65/NPS 2½		0500		DN 500/NPS 20								
0080	DN 80/NPS 3		0600		DN 600/NPS 24								
0100	DN 100/NPS 4		0700		DN 700/NPS 28								
0125	DN 125/NPS 5		0750		DN 750/NPS 30								
0150	DN 150/NPS 6		0800		DN 800/NPS 32								
0200	DN 200/NPS 8		0900		DN 900/NPS 36								
Body													
D0	Ductile iron												
Disc	S1 304 stainless steel												
D0	Ductile iron - ENP												
D1	Ductile iron - epoxy												
D2	Ductile iron - nylon												
D3	Ductile iron - FBE ⁽³⁾ ctd												
S0	316 stainless steel												
Shaft													
S0	316 stainless steel ⁽¹⁾												
S2	431 stainless steel												
U0	Duplex												
Seat													
E0	EPDM FG (NSF ANSI/61 & ACS)												
E1	EPDM (WRAS, KWIA, ACS)												
E6	EPDM reinforced (DN 350-600, NPS 14-24)												
H1	HNBR												
N0	NBR FG												
N1	NBR (DVGW-G)												
N8	NBR reinforced (DN 350-600, NPS 14-24)												
N9	White NBR												
F1	FKM												
Flange drilling													
Single drilled lug and wafer													
A1	ASME 125/150												
J1	JIS B2210 - 10K												
P1	PN 6												
P2	PN 10												
P3	PN 16												
PA	PN 6/10/16												
PB	PN 10/16												
Multi drilled wafer													
M1	PN 10/16, ASME 125/150, BS EJIS10												
M2	PN10/16, ASME 125/150, BS E												
MB	PN 6/10/16, ASME 125/150												
MC	PN 10/16												
Actuator mounting													
I	ISO 5211 mount												
Actuation													
00	None												
H1	10 pos handle - blue												
G1	Gear - blue												
G5	Chainwheel - blue												
Special													
000	None												
P04	Reduced disc for 50 dpi												
C22	NSF/ANSI std 61												
009	Silicone free												
Coating													
00	Standard blue												
02	C3 blue ctd body												
03	C5M blue ctd body												
04	FBE blue ctd body												

NOTES

1. The standard shaft material is 431 stainless steel. 316 SS is only available as an option on DN 50-300 (NPS 2-12).

2. All disc screws will be of duplex except for super duplex disc which will have a super duplex disc screw.

3. FBE = Fusion bond epoxy

Other options are available on request. Please consult your local sales representative.

Monel® is a registered trademark of the Special Metals Corporation.

KEYSTONE SERIES GR RESILIENT SEATED BUTTERFLY VALVES

GRW/GRL (ISO)

FLANGE ACCOMMODATION CHART FOR WAFER VALVES

Drillings	Sizes (DN)													
	20	Ord. code	25	Ord. code	32	Ord. code	40	Ord. code	50-500	Ord. code	600	Ord. code	700-900	Ord. code
PN 6	NA	-	STD	MB	NA	-	STD	MB	Mod.	P1	Mod.	P1	Mod.	P1
PN 10	STD	MC	STD	MB	STD	MC	STD	MB	STD	M1	STD	M2	A-o	P2
PN 16	STD	MC	STD	MB	STD	MC	STD	MB	STD	M1	STD	M2	A-o	P3
ASME 125/150	NA	-	STD	MB	NA	-	STD	MB	STD	M1	STD	M2	A-o	A1
BS Table E	NA	-	NA	-	NA	-	STD	MB	STD	M1	STD	M2	A-o	B1
JIS 10K	NA	-	NA	-	NA	-	STD	MB	STD	M1	NA	-	A-o	J1

FLANGE ACCOMMODATION CHART FOR LUG VALVES

Drillings	Sizes (DN)													
	20	Ord. code	25	Ord. code	32	Ord. code	40	Ord. code	50-500	Ord. code	600	Ord. code	700-900	Ord. code
PN 6	NA	-	NA	-	NA	-	STD	PA	A-o	P1	A-o	P1	A-o	P1
PN 10	STD	PB	STD	PB	STD	PB	STD	PA	A-o	P2	A-o	P2	A-o	P2
PN 16	STD	PB	STD	PB	STD	PB	STD	PA	A-o	P3	A-o	P3	A-o	P3
ASME 125/150	NA	-	STD	A1	NA	-	STD	A1	A-o	A1	A-o	A1	A-o	A1
BS Table E	NA	-	NA	-	NA	-	NA	-	A-o	B1	A-o	B1	A-o	B1
JIS 10K	NA	-	NA	-	NA	-	NA	-	A-o	J1	NA	-	A-o	J1

Mod. = Modifications required - Is possible but will require some modifications and will be a special

STD = Standard valve locating plate is multi drilled and covers this flange standard

A-o = As ordered - All valves have to be ordered as this drilling using the code above

NA = Not possible on this valve size